

14"X43" VARIABLE SPEED WOOD LATHE

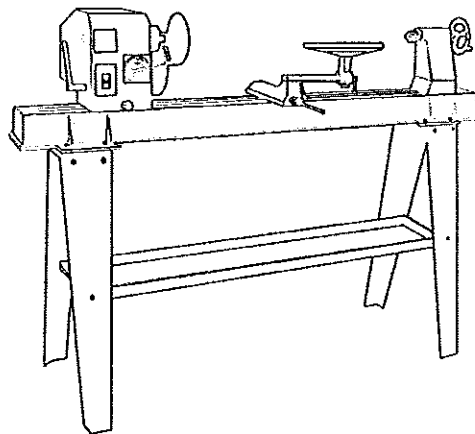

INSTRUCTION MANUAL

TABLE OF CONTENTS

SECTION.....	PAGE
Technical data.....	1
General safety rules.....	1-3
Specific safety rules for wood lathe.....	3
Electrical information.....	4
Assembly.....	4-6
Adjustments.....	7
Operation.....	7-8
Maintenance.....	9
Wiring diagram.....	10
Parts diagram.....	11
Parts list.....	12

TECHNICAL DATA

Model number.....	MC1100
Motor.....	550W or 750W
Speeds.....	500-2000RPM
Distance between centers	1100mm
Swing over bed.....	355mm
Drive spindle	M33X3.5 or 1"X8 TPI or other
Drive spindle through hold	10mm
Tailstock spindle through hole.....	10mm
Tailstock spindle travel.....	57mm
Net weight.....	92kgs
Noise.....	68dB(A)

GENERAL SAFETY RULES

WARNING! WHEN USING ELECTRIC TOOLS BASIC SAFETY PRECAUTIONS SHOULD ALWAYS BE FOLLOWED TO REDUCE THE RISK OF FIRE ELECTRIC SHOCK AND PERSONAL INJURY INCLUDING THE FOLLOWING.

Read all these instructions before attempting to operate this product and save these instructions.

SAFETY RULES

1. Keep work area clear

Cluttered areas and benches invite injuries.

2. Consider work area environment

Do not expose tools to rain. Do not use tools in damp or wet locations. Keep work area well lit.

Do not use tools in the presence of flammable liquids or gases.

3. Guard against electric shock

Avoid body contact with earthen or grounded surfaces.

4. Keep other persons away

Do not let persons especially children not involved in the work touch the tools or the extension cord and keep them away from the work area.

5. Store Idle tools

When not in use, tools should be stored in a dry locked up place out of reach of children.

6. Do not force the tool

It will do the job better and safer at the rate for which it was intend.

7. Use the right tool

Do not force small tools to do the job of a heavy-duty tool.

8. Dress properly

Do not wear loose clothing or jewelry, they can be caught in moving parts. Non-skid footwear is recommended when working outdoors. Wear protective hair covering to contain long hair.

9. Use protective equipment

Use safety glasses. Use face or dust mask if cutting operations create dust.

10. Connect dust extraction equipment

If device are provided for the connection do dust extraction and collecting equipment. Ensure these are connected and properly used.

11. Do not abuse the cord

Never rank the cord to disconnect it from the socket. Keep the cord away from heat oil and sharp edges.

12. Secure work

Where possible use clamps or a vice to hold the work, it is safer than using your hand.

13. Do not overreach

Keep proper footing and balance at all times.

14. Maintain tools with care

Keep tools sharp and clean for better and safer performance.

Follow instructions for lubricating and changing accessories.

Inspect tool cords periodically and if damaged have them repaired by an authorized service facility.

15. Disconnect tools

When not in use, before servicing and when changing accessories such as blades, bits and cutters, disconnect tools from the power supply.

16. Remove adjusting keys and wrenches.

Form the habit of checking to see that keys and adjusting wrenches are removed from the tool before turning it on.

17. Avoid unintentional starting

Ensure switch is in "off" position when plugging in.

18. Use outdoor extension leads

When the tool is used outdoors use only extension cords intended for outdoor use and marked.

19. Stay Alert

Watch what you are doing using common sense and do not operate the tool when you are tired.

20. Check damaged parts

Before further use of tool, it should be carefully checked to determine that it will operate properly and perform its intended function.

Check for alignment of moving parts, binding of moving parts, breakage of parts, and any other conditions may affect its operation.

A guard or other part that is damaged should be properly repaired or replaced by an authorized service center unless otherwise indicated in this instruction manual.

Have defective switches replaced by an authorized service center.

Do not use the tool if the switch does not turn it on and off.

21. Warning!

The use of any accessory or attachment other than on recommended in this instruction manual may present a risk of personal injury.

22. Have your tool repaired by a qualified person

Repairs should only be carried out by a qualified person using original spare parts, otherwise may result in considerable danger to the user.

Specific safety rules for the wood lathe

WARNING! Do not operate your wood lathe until it is completely assembled and installed according to the instructions.

1. For your own safety, read the entire instruction manual before operating the lathe.
2. Always wear eye protection.
3. Do not wear gloves, necktie, or loose clothing.
4. Tighten all locks before operating.
5. Do not mount a split workplace.
6. Use the lowest speed when starting a new workpiece.
7. Read the warning label attached to the wood lathe.
8. When turning a workpiece, always rough the wood to round form please stop wood lathe at slow speed. If the lathe is run so fast that it vibrates, there is a risk that the workplace will be thrown or the tool jerked from your hands.
9. Always rotate the workplace by hand before turning on the lathe. If the workpiece strikes the tool rest, it could split and be thrown out of the lathe.
10. Do not allow the turning tools to bite into the wood. The wood could split or be thrown from the lathe.
11. Always position the tool rest above the centerline of the lathe when shaping a piece of stock.
12. Do not operate the lathe if it is rotating in the wrong direction.
The workpiece must always be rotating toward you.
13. Before attaching a workpiece to the faceplate, always rough it out to make it as round as possible, this minimizes the vibrations while the piece is being turned. Always fasten the workpiece securely to the faceplate, failure to do this could result in the workpiece being thrown away from the lathe.
14. Position your hands so that they will not slip onto the workpiece.
15. Remove all loose knobs in the stock before mounting between the centers or on the faceplate.

Save these safety rules!

Electrical information

Guidelines for using extension cords

WARNING! THIS WOOD LATHE IS FOR INDOOR USE ONLY. DO NOT EXPOSE TO RAIN OR USE IN DAMP LOCATIONS.

Make sure your extension cord is in good condition. When using an extension cord, be sure to use one heavy enough to carry the current your product will draw. An undersized cord will cause a drop in line voltage resulting in loss of power and overheating. The table below shows the correct size to use according to cord length and nameplate ampere rating. If in doubt, use the next heavier gauge.

Extension lead sizes shown assure a voltage drop of not more than 5% at rated load of tool.

Ampere rating (on name plate)	3	6	10	13
Extension cable length	Wire size mm ²			
7.5m	0.75	0.75	1.0	1.25
15m	0.75	0.75	1.0	1.5
22.5m	0.75	0.75	1.0	1.5
30m	0.75	0.75	1.25	1.5
45m	0.75	1.25	1.5	2.5

WARNING! THIS TOOL MUST BE GROUNDED WHILE IN USE TO PROTECT THE OPERATOR FROM ELECTRICAL SHOCK.

SAVE THESE SAFETY RULES!

Assembly

Unpacking (Fig 1)

1. Carefully remove the leg set and wood lathe from the carton.

CAUTION! THE WOOD LATHE IS VERY HEAVY AND MUST BE LIFTED WITH THE HELP OF 2 PEOPLE OR MORE. THE ASSEMBLY PROCESS REQUIRES 2 PEOPLE OR MORE TO SAFELY ASSEMBLE THE LATHE TO THE LEG SET.

2. Separate the parts for the leg set from the parts of the lathe.
3. Lay out all parts and check them against the parts listed below. Examine all parts carefully.

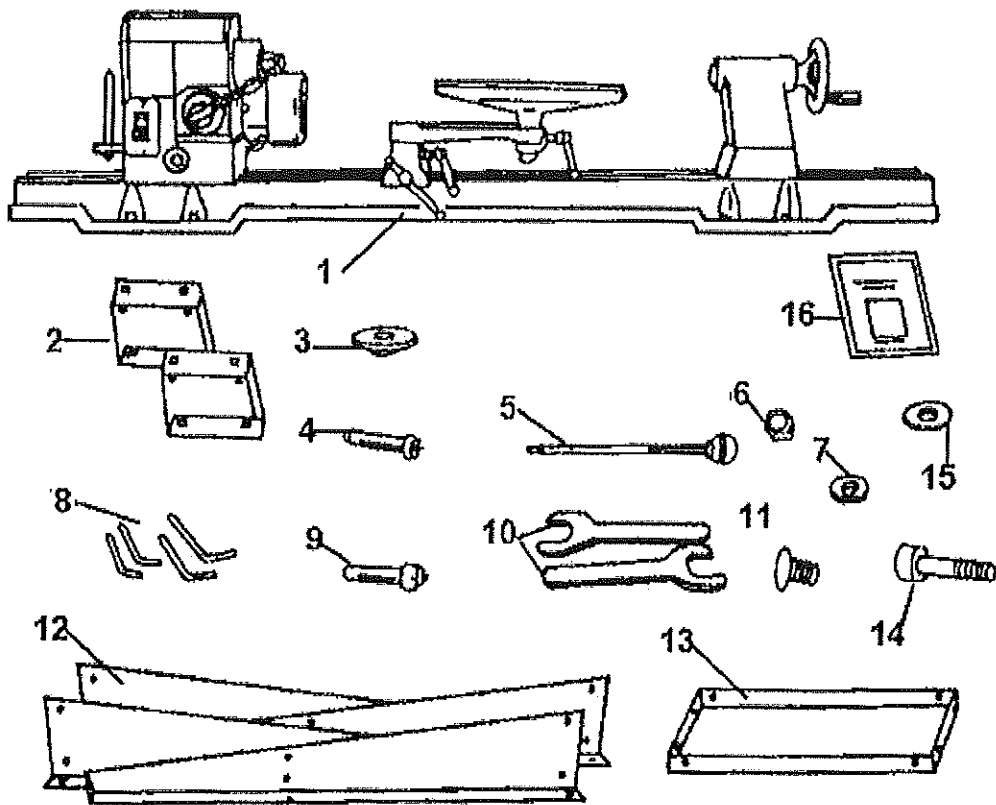

- | | |
|----------------------------|---|
| 1 – Lathe Bed assembly | 9 – Tailstock Cup Center |
| 2 – Top Leg Plates | 10 – 32mm Wrenches(1 or 2 pcs supplied) |
| 3 – Faceplate | 11 – 24 Carriage Bolts |
| 4 – Headstock Spur Center | 12 – 2 Front and 2 Back legs |
| 5 – Push Rod | 13 – Middle Partition |
| 6 – 32 Nuts | 14 – 8 Hex Bolts |
| 7 – 6 Lock Washers | 15 – 24 Flat Washers |
| 8 – 4 Hexkeys 3, 4, 6, 8mm | 16 – Manual |

WARNING! IF ANY PART IS MISSING OR DAMAGED, DO NOT PLUG THE WOOD LATHE IN UNTIL YOU HAVE REPLACED THE MISSING OR DAMAGED PART.

For your safety, complete the assembly of the lathe before plugging it into the power supply.

Assembly

Setting the lathe on the leg set (Fig 3)

1. Place the lathe bed assembly [1] on the leg set.
2. Position the headstock [2] assembly over the top plate and align the holes in the bed [3] with the holes in the top plate [4]. Set the head stock down carefully.
3. Align the tailstock assembly end of the lathe over the top plate mounting holes and set it down carefully.
4. Insert the hex bolts [5] into the mounting holes in each bed and tighten securely.

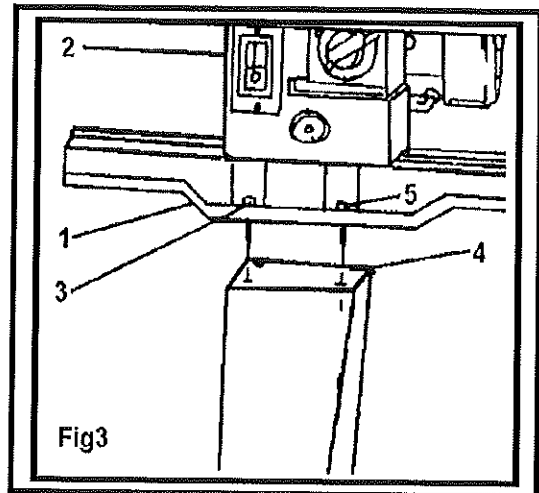

IMPORTANT! THE LEG SET MUST BE FASTENED TO THE SUPPORTING SURFACE.

Faceplate (Fig 4)

1. Remove the headstock spur from the spindle.
2. Thread the 6 inch diameter faceplate to the Spindle.
3. Mount the workpiece to the faceplate with the flat head brass wood screws. Make sure the length of the screws does not interfere with the cutting tools.

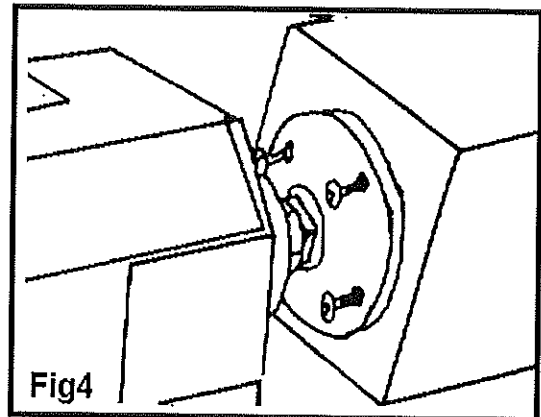

Spurs

1. Remove the faceplate [1] from the headstock spindle using the wrench and push rod provided [2] to separate the faceplate from the spindle nut. (Fig5)
When drive spindle is 1"x8 TPI, please use two-wrench to separate the faceplate.
2. Insert the headstock spur [3] in the spindle hole.
3. Insert the live center [4] in the tailstock hole. (Fig 6)
4. To remove either the headstock spur or the tailstock center insert the push-out rod [5] into the hole [6] at the opposite end of the headstock or tailstock. Remove and store the rod in a safe location after use.

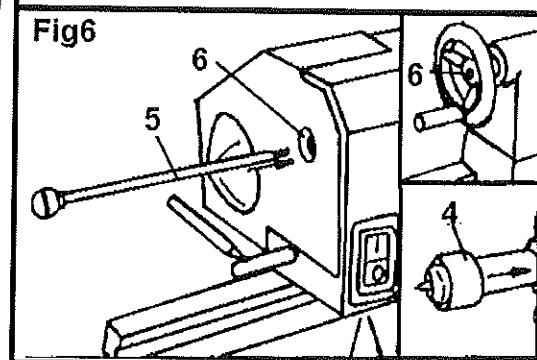
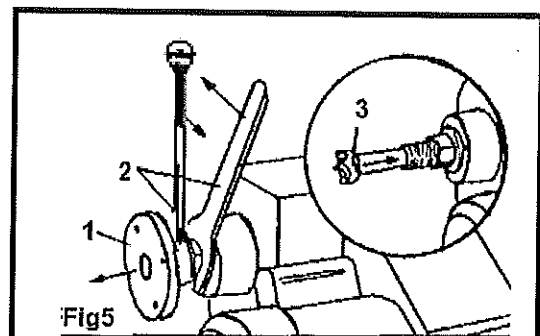

WARNING! Do not operate your wood lathe until it is completely assembled and adjusted according to the instructions.

Adjustments

Headstock (Fig 7)

1. The headstock has 5 preset positions, 0° setting for all spindle turning applications, $60^{\circ}/90^{\circ}/120^{\circ}$ for use when making face plate turnings, 180° for use for face plate turnings when using the extension bed and tool rest.
2. To set the headstock at the desired position, you must first turn the head lock handle [1] until you have completed at least one rotation. (Fig 8)
3. Pull out the headstock release [2], rotate the entire headstock clockwise to the desired position. The headstock will be fixed in position when it clicks into one of the five pre-set settings. Tighten the lock handle [1].

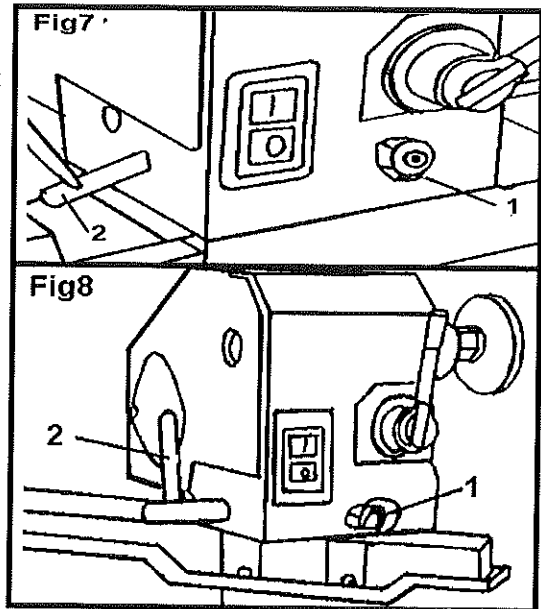

Operation

Switch (Fig 9)

1. The lathe is fitted with a no-volt switch. In the event of a power supply failure the wood lathe need to be manually re-started by pushing the "I" button on the switch.
2. Lock switch (Alternative)
 - a. To turn the lathe 'on', insert the yellow switch key into the switch housing.
 - b. Move the switch to the 'on' position.
 - c. To turn the lathe 'off', move the switch to the 'off' position.
 - d. To lock the switch in the 'off' position, remove the yellow switch key and store it in a safe place.
3. NEVER leave a running lathe unattended.

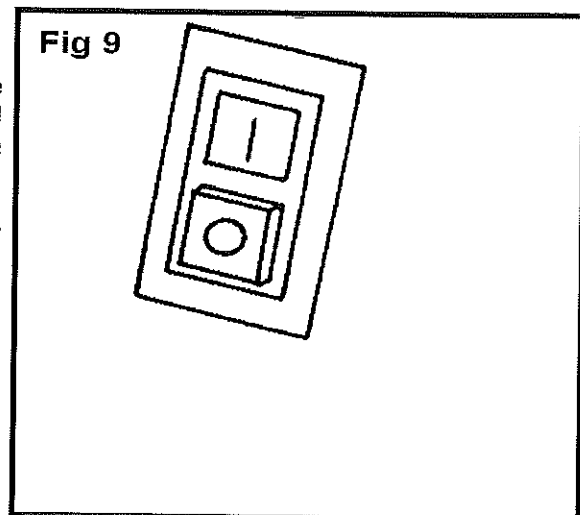

Speed control (Fig 10)

1. The lathe motor must be running before you can use the speed control lever.
2. The speed control lever can be turned to one of ten fixed speeds. To set the speed, pull back on the lever handle [1] and rotate the handle to the next fixed speed. Use the index plate [2] to choose right lathe speed.
3. Turn the lever clockwise to increase the speed and turn counterclockwise to decrease the speed.
4. You must move the speed control lever to the lowest speed setting before turning the switch off (Fig 11), otherwise the motor may not start or be damaged.

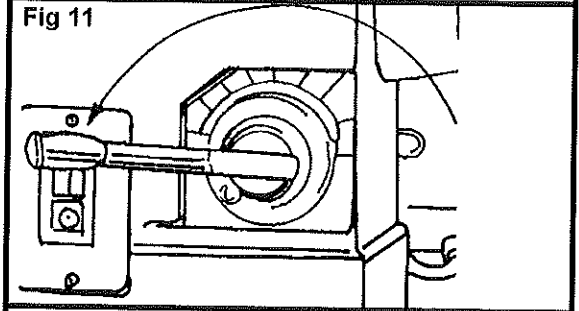
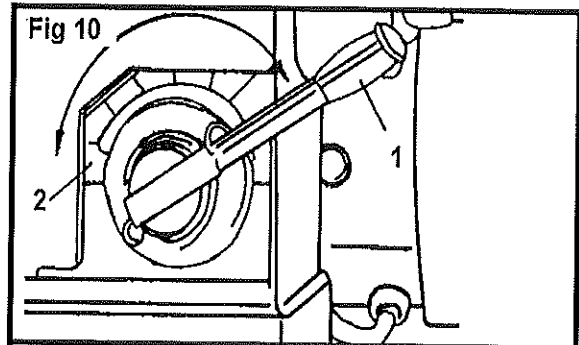

Tailstock (Fig 12)

1. Move the tailstock [1] by loosening turning the lock lever [2] and pushing the tailstock to the desired position on the bed. Lock by tightening the lock lever [2].
2. The spindle can extend up to 6.35cm from the tailstock housing. You can move the tailstock spindle [3] by loosening the spindle lock lever [4] and then turning the hand wheel [5]. Lock levers [4] and [2] before operating lathe.
3. The tailstock spindle is hollow and can be accessed from the hand wheel end. Use the push-out rod to remove the center cup or to drill holes through the center of a workplace.

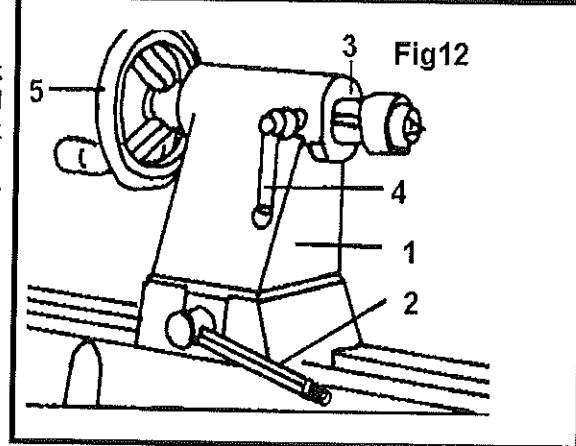

Tool rest (Fig 13)

1. The tool rest [1] can be used with or without the arm [2].
2. To move the tool rest base [3], loosen the lock lever [4], and move the base to the right or left and back or front. Tighten the lever [4] when the tool rest base is in the desired position.
3. When using the arm [2], make the necessary adjustments using lock levers [5] and [6] to position the tool rest.
4. Tighten all tool rest lever handles [4-5-6] and ensure there is adequate clearance between the workplace and the tool rest assembly before turning the lathe on.
5. The tool rest can also be repositioned to the extension bed for use on outboard turnings. (Fig 14)

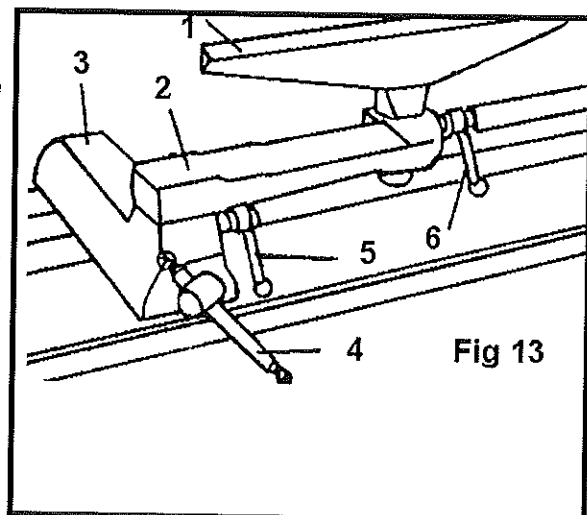

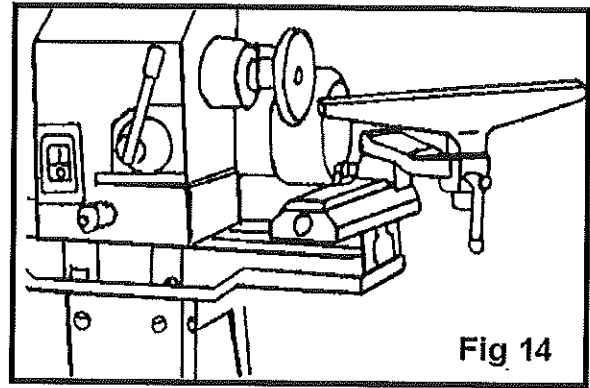

IMPORTANT! MAKE SURE THE TOOL REST IS ADJUSTED TO BE AS CLOSE TO THE WORKPLACE AS POSSIBLE. ROTATE THE WORKPLACE BY HAND TO CHECK CLEARANCE BEFORE TURNING THE LATHE ON.

Maintenance

WARNING - FOR YOUR OWN SAFETY, TURN THE LATHE OFF AND DISCONNECT THE POWER PLUG FROM THE POWER SOURCE BEFORE PERFORMING ANY MAINTENANCE OR LUBRICATION WORK ON THE LATHE.

- Vacuum and/or blow out any dust accumulation inside the motor housing on a regular basis.
- Apply a coat of paste wax to the lathe bed to help keep it clean and to facilitate the easy movement of the articulated tool rest and tailstock.
- Proper Oiling and maintenance must take place to ensure the quality and life of the machine. To Maintain this, the use of a pin point oiler would be helpful. Take the headstock cover off, and oil the point in the diagram. This should be done periodically.

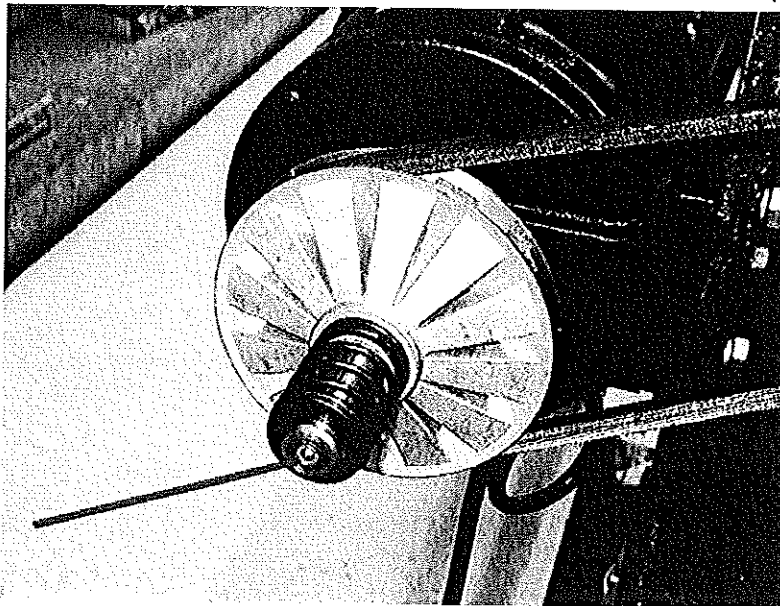

Periodic lubrication (white grease) of the spring levers and other threaded parts will make them easier to operate and prevent any possible corrosion.

.Wiring diagram

1. 220-240V/50Hz, 1 Phase

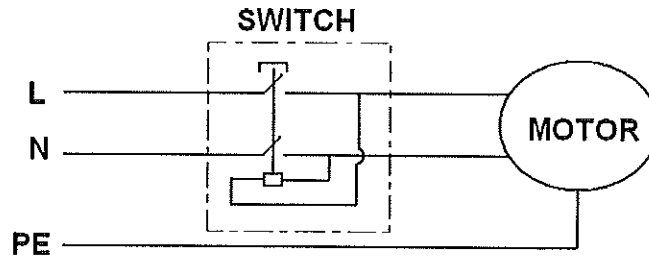

2. 380-400V/50Hz, 3 Phase

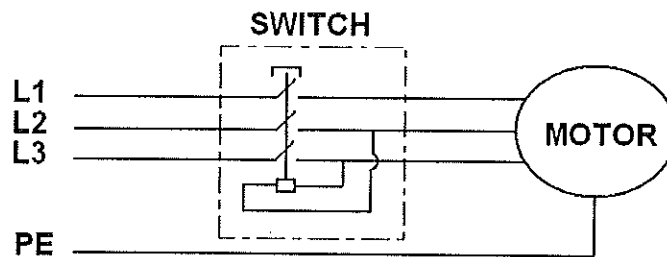

3. 110-120V/60Hz, 1 Phase

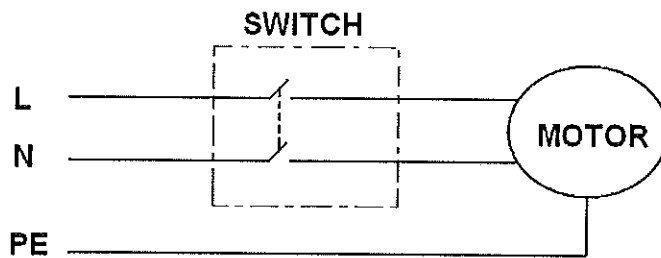

Note:

Products improving all the time, design and parameter changes without prior notice. Please refer to the sample.

WOOD LATHE PARTS LIST

NO.	DESCRIPTION	Q'TY	NO.	DESCRIPTION	Q'TY
1	HEADSTOCK	1	43	CLAMP-A	1
2	FACE PLATE	1	44	HEX NUT	3
3	HEADSTOCK SPUR	1	45	ANGULAR SETTING ASSEMBLY	1
4	SPINDLE	1	46	SCREW	2
5	KEY	1	47	SPRING WASHER	2
6	BEARING	2	48	GEAR ASSEMBLY	1
7	"C"RING	2	49	SPEED LABLE	1
8	SPRING	1	50	INSTRUCTION MANUAL	1
9	BRACKET-SHIFTING LEVER	1	51	HEX SCREW	3
10	"C"RING	1	52	BACK	1
11	"C"RING	1	53	BOLT-B	2
			54	CLAMP-B	2
13	MOTOR	1	55	ECCENTRIC ROD	1
14	KEY	1	56	TOOL REST BODY	1
15	SCREW	1	57	HANDLE ASSEMBLY	2
16	COVER-MOTOR	1	58	EXTENSION TOOL REST	1
17	PULLEY-MOTOR(RIGHT & LEFT)	1	59	LOCK HANDLE-TAILSTOCK	1
			60	TOOL REST	1
19	SPRING	1	61	TAILSTOCK SPUR	1
20	SLEEVE	1	62	TAIL SPINDLE	1
21	"C"RING	2	63	TAIL STOCK SCREW	1
22	PUSH-OUT ROD	1	64	HANDLE ASSEMBLY	1
23	KNOB	2	65	TAILSTOCK	1
24	"C"RING	3	66	WASHER	1
25	ECCENTRIC ROD	1	67	HANDLE WHEEL	1
26	SCREW	1	68	SCREW	1
27	"C"RING	1	69	SCREW	1
28	PULLEY-SPINDLE(LEFT & RIGHT)	1	70	STAND UPPER COVER	2
29	V-BELT	1	71	STAND LEG, LEFT	2
			72	STAND LEG, RIGHT	2
31	BEARING	1	73	PLATE	1
32	NUT-LOCK	1	74	SWITCH	1
33	NUT	9	75	SWITCH BOX	1
34	CLAMP	2	76	POWER CORD	1
35	NUT M4x40	2	77	CARRIAGE BOLT M8 x 12	20
36	"C"RING	1	78	WASHER 8MM	20
37	TURNING BASE	1	79	WASHER 8MM	8
38	BED	1	80		
39	BAFFLE	2	81	COVER	1
40	SCREW	4	82	PLASTIC JAM NUT M20 X 1.5	1
41	HEX WRENCH	4	83	Screw	2
42	BOLT-A	1	84		

WOOD LATHE PARTS DIAGRAM

