

# MC1018(1039) MODEL VARIABLE SPEED WOOD LATHE

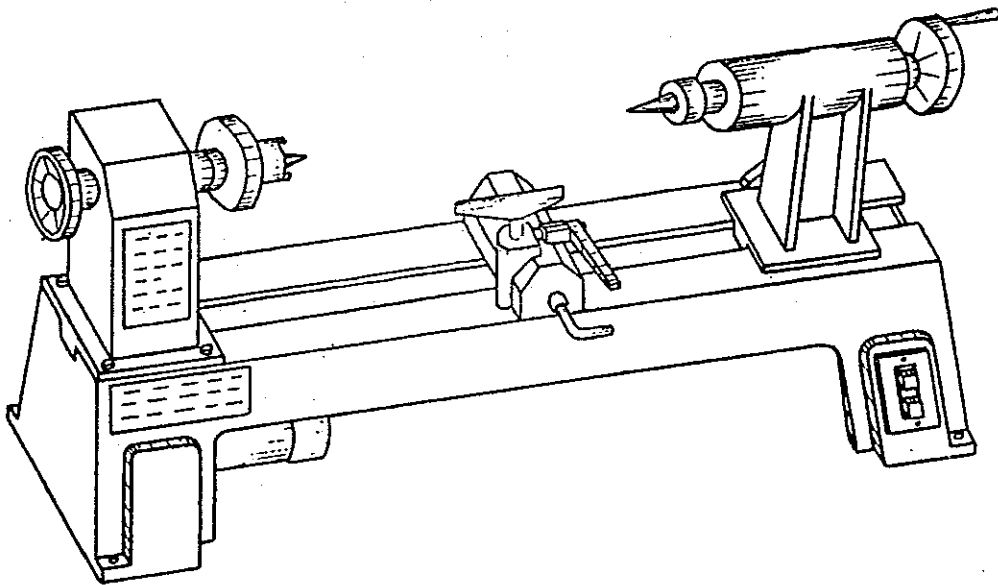

INSTRUCTION MANUAL

**Before Using Be Sure To Read This Manual**

## I Technical data

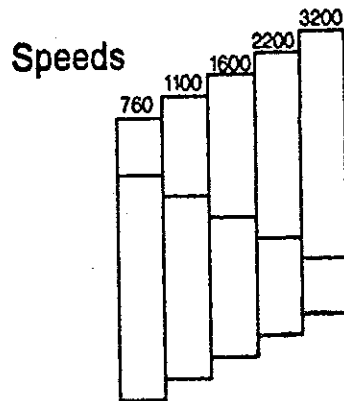

### **MC1018**

Distance Between Centers 18"

Turning diameter 10"

motor 370w

Netgross Weight 38/41kg

## II General safety rules

Safety is a combination of common sense, staying alert and knowing how your wood lathe works.

**WARNING: TO AVOID MISTAKES THAT COULD CAUSE SERIOUS INJURY,  
DO NOT PLUG THE WOOD LATHE IN UNTIL THE FOLLOWING STEPS  
HAVE BEEN READ AND UNDERSTOOD.**

1. READ and become familiar with this entire instruction manual. Learn the tool's applications, limitations, and possible hazards.
2. AVOID DANGEROUS CONDITIONS. DO NOT use power tools in wet or damp areas or expose them to rain. Keep work area well lit.
3. DO NOT use power tools in the presence of flammable liquids or gases.
4. ALWAYS keep your work area clean, uncluttered and well lit. DO NOT work on floor surfaces that are slippery with sawdust or wax.
5. KEEP BYSTANDERS AT A SAFE DISTANCE FROM the work area, especially when tool is operating. NEVER allow children near the tool.
6. DO NOT FORCE THE TOOL to do a job for which it was not designed.
7. DRESS FOR SAFETY. DO NOT wear loose clothing, gloves, neckties, or jewelry (rings, watches) when operating tool. They can get caught and draw you into moving parts. ALWAYS wear non-slip footwear, and tie back long hair.
8. WEAR A FACE MASK OR DUST MASK. Wood lathe operation produces dust.

9. ALWAYS remove the power cord plug from the electrical outlet when making adjustments, changing parts, cleaning or working on tool.
10. AVOID ACCIDENTAL START-UPS. Make sure that the power switch is in the "OFF" position before plugging in the power cord.
11. REMOVE ADJUSTING TOOLS. ALWAYS MAKE SURE all tools are removed from the wood lathe before turning it on.
12. NEVER LEAVE A RUNNING TOOL UNATTENDED. Turn the power switch to "OFF". DO NOT leave tool until it has come to a complete stop.
13. NEVER STAND ON A TOOL. Serious injury could result if the tool tins or is accidentally hit DO NOT store anything above or near the tool.
14. DON'T OVERREACH. Keep proper footing and balance at all times. Wear oil-resistant rubber-soled footwear. Keep floor clear of oil scrap and other debris.
15. MAINTAIN TOOLS PROPERLY. ALWAYS keep tools clean and in good working order. Follow instructions for lubricating and changing accessories.
16. CHECK DAMAGED PARTS. Check for alignment of moving parts, binding of moving parts, breakage of parts, improper mounting or any other conditions that may affect the tools operation. Any part that is damaged should be properly repaired or replaced before use.
17. MAKE WORKSHOP CHILDPROOF. Use padlocks, master switches, and ALWAYS remove starter keys.
18. DO NOT operate tool if you are under the influence of any drugs, alcohol or medication that could affect your ability to use the tool properly.
19. WARNING. Dust penetrated from certain materials can be hazardous to your health. Always operate lathe in a well-ventilated area and provide for proper dust removal. Use dust collection systems whenever possible.

### III Specific safety rules for the wood lathe

WARNING; DO NOT OPERATE YOUR WOOD LATHE UNTIL IT IS COMPLETELY ASSEMBLED AND INSTALLED ACCORDING TO THE INSTRUCTIONS.

1. For your own safety, read the entire instruction manual before operating the lathe.
2. ALWAYS wear eye protection.
3. Do not wear gloves, necktie, or loose clothing.
4. Tighten all locks before operating.
5. Do not mount a split workpiece.

6. Use the lowest speed when starting a new workpiece.
7. Read the warning label attached to the wood lathe.
8. When turning a workpiece, always rough the wood to round form at slow speed. If the lathe is run so fast that it vibrates, there is a risk that the workpiece will be thrown or the tool jerked from your hands.
9. Always rotate the workpiece by hand before turning on the motor. If the workpiece strikes the tool rest, it could split and be thrown out of the lathe.
10. Do not allow the turning tools to bite into the wood. The wood could split or be thrown from the lathe.
11. Always position the tool rest above the centerline of the lathe when shaping a piece of stock.
12. Do not operate the lathe if it is rotating in the wrong direction. The workpiece must always be rotating toward you.
13. Before attaching a workpiece to the faceplate, always rough it out to make it as round as possible. This minimizes the vibrations while the piece is being turned. Always fasten the workpiece securely to the faceplate. Failure to do so could result in the workpiece being thrown from the lathe.
14. Position your hands so that they will not slip onto the workpiece.
15. Remove all loose knots in the stock before mounting it between the centers or on the faceplate.
16. Leave the work area only after the lathe's motor has come to a full stop.
17. Hang your turning tools on the wall beyond the tailstock end of the lathe. Do not lay them on the bench so that you must reach over the revolving workpiece to select them.
18. Keep a firm hold and remain in control of the cutting tool at all times. Take special precautions when shaping a section of stock in which knots or voids are found.
19. Always make safety come first.
20. Complete the hand-sanding of all workpieces BEFORE you remove them from the lathe.

## IV ADJUSTING THE MAIN SPINDLE'S SPEED

According to the work piece's requirement, you can easily adjust the main, spindle's speeds.

First open the back lid(20#) of headstock(19#). Loosen the socket head bolt(33#), take out the motor plate(31#), then change the speed by moving the drive belt(26#).

When finishing changing, fix the socket head bolt(33#) to motor plate(31#) and tighten them, fix the back lid(20#) to the head stock(19#) with the four semiedrcle head crews (21#) and washer( $\phi 5$ ).

### SAVE THESE SAFETY RULES

#### V Electrical information

##### GROUNDING INSTRUCTIONS

IN THE EVENT OF A MALFUNCTION OR BREAKDOWN, grounding provides the path of least resistance for electric current to reduce the risk of electric shock. This tool is equipped with an electric cord that has an equipment grounding conductor and a grounding plug. The plug MUST be plugged into a matching outlet that is properly installed and grounded in accordance with ALL local codes and ordinances.

DO NOT MODIFY THE PLUG PROVIDED. If it will not fit in the outlet, have the proper outlet installed by a qualified electrician.

IMPROPER CONNECTION of the equipment grounding conductor can result in risk of electric shock. The conductor with the green insulation (with or without yellow stripes) is the equipment grounding conductor. If repair or replacement of the electric cord or plug is necessary, DO NOT connect the equipment grounding conductor to a live terminal.

CHECK with a qualified electrician or service person if you do not completely understand the grounding instructions, or if you are not sure the tool is properly grounded.

USE ONLY THREE WIRE EXTENSION CORDS that have 3-prong grounding type plugs and 3-hole receptacles that accept the tool's plug as shown in Fig. A. Repair or replace damaged or worn cord immediately.

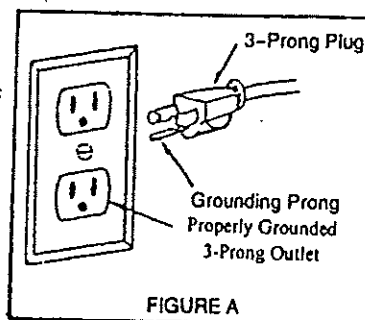

CAUTION: IN ALL CASES, MAKE CERTAIN THE RECEPTACLE IN QUESTION IS PROPERLY GROUNDED. IF YOU ARE NOT SURE, HAVE A CERTIFIED ELECTRICIAN CHECK THE RECEPTACLE.

#### VI WIRING DIAGRAM

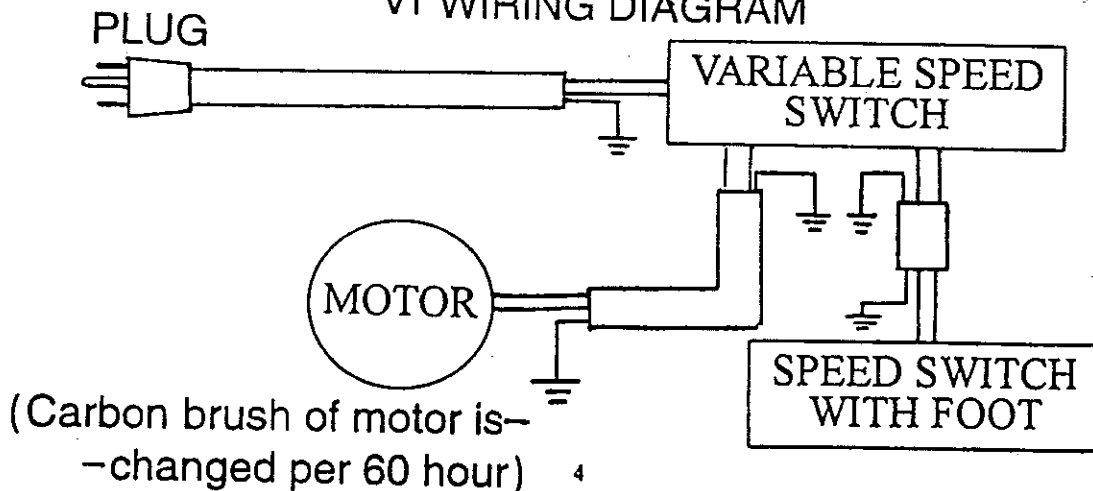

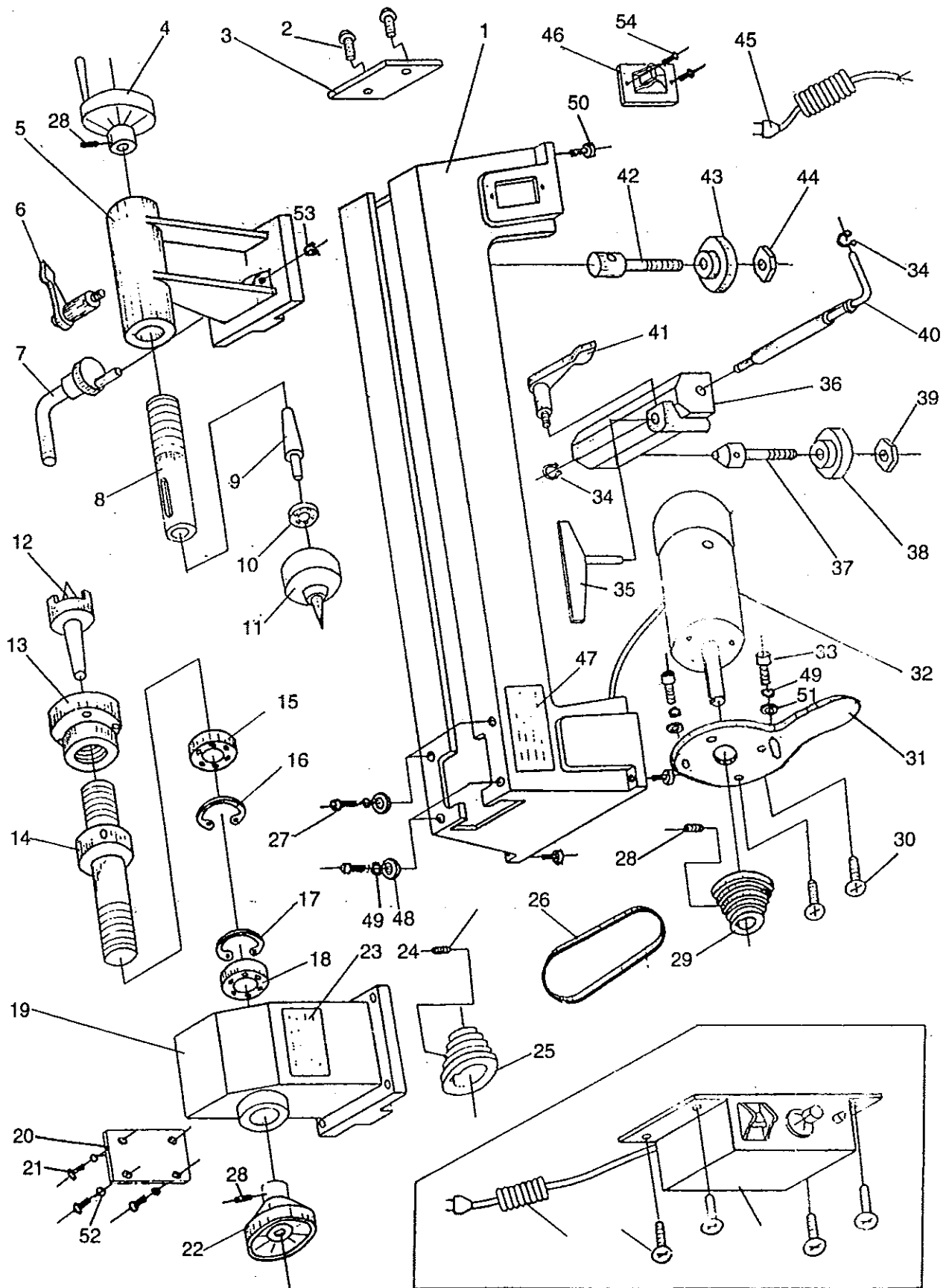

PART LIST FOR DIAGRAM OF MC1018

| PART NO. | DESCRIPTION                    | QTY |
|----------|--------------------------------|-----|
| 1        | Bed                            | 1   |
| 2        | Semicircle Head Screw          | 2   |
| 3        | Retaining Plate                | 1   |
| 4        | Handwheel                      | 1   |
| 5        | Tailstock                      | 1   |
| 6        | Lock Lever                     | 1   |
| 7        | Eccentric Axis                 | 1   |
| 8        | Tail Axis                      | 1   |
| 9        | Taper Rod                      | 1   |
| 10       | Bearing Ball                   | 1   |
| 11       | Cup Center                     | 1   |
| 12       | Headstock Spur Center          | 1   |
| 13       | Faceplate                      | 1   |
| 14       | Headstock Spindle              | 1   |
| 15       | Bearing Ball                   | 2   |
| 16       | Ring Retaining                 | 1   |
| 17       | Ring Retaining                 | 1   |
| 18       | Bearing Ball(202)              | 1   |
| 19       | Headstock                      | 1   |
| 20       | Back Lid                       | 1   |
| 21       | Semicircle Head Screw          | 4   |
| 22       | Balance Wheel                  | 1   |
| 23       | Marking Plate                  | 1   |
| 24       | Hex. Socket Set Screw          | 1   |
| 25       | Drive Pulley                   | 1   |
| 26       | Drive Belt                     | 1   |
| 27       | Hex. Socket Head Screw M8 × 25 | 1   |
| 28       | Hex. Socket Set Screw M6 × 10  | 1   |
| 29       | Motor Pulley                   | 1   |
| 30       | Flat Head Screw                | 2   |
| 31       | Motor Plate                    | 1   |
| 32       | Motor                          | 1   |

|    |                                |   |
|----|--------------------------------|---|
| 33 | Hex. Socket Head Screw M8 × 20 | 1 |
| 34 | Ring Retaining 12              | 2 |
| 35 | Tool Rest                      | 1 |
| 36 | Tool Rest Base                 | 1 |
| 37 | Bolt                           | 1 |
| 38 | Plate                          | 1 |
| 39 | Hex. Nut                       | 1 |
| 40 | Lock Handle For Knife Base     | 1 |
| 41 | Lock Lever                     | 1 |
| 42 | Bolt                           | 1 |
| 43 | Lock Plate                     | 1 |
| 44 | Hex. Nut                       | 1 |
| 45 | Power Cord                     | 1 |
| 46 | Switch                         | 1 |
| 47 | Warning Label                  | 1 |
| 48 | Washer 8                       | 4 |
| 49 | Spring Washer 8                | 6 |
| 50 | Rubber Washer                  | 4 |
| 51 | Big Washer 8                   | 2 |
| 52 | Washer 5                       | 4 |
| 53 | Ring Retaining 10              | 1 |
| 54 | Semicircle Head Screw M5 × 10  | 2 |